



ENVIRO  
BUILD

# HYPERION<sup>®</sup>

C L A D D I N G

PIONEER

INSTALLATION &  
MAINTENANCE GUIDE

# CONTENTS

Storage and Handling	3
Tools	4
Calculating Materials	5
Installation - Spacing	7
Installing Cladding Supports	9
Installation - Horizontal Cladding	10
Installation - Vertical Cladding	13
Installation - Finishing	14
Doors and Windows - Fascia Boarding	15
Doors and Windows - Corner Trims	16
Doors and Windows - Edge Board	17
FAQs	19
Maintenance & Care	20

It is the customer's responsibility to determine the suitability of Hyperion Cladding for their particular private or commercial installation. It is solely the customer's responsibility to consult with their local building control to determine fire classification project requirements.



# STORAGE & HANDLING

While composites are highly durable, to ensure their lasting beauty, please follow these important guidelines when storing, moving and working with Hyperion Cladding products



## STORAGE

- Material should always be covered until it is ready to be installed to maintain a clean surface. If stored outside use a non-translucent material
- All products should be stored flat and level, supported above the ground at 500mm intervals
- Battens used to separate and support any stored cladding material should be spaced no more than 500mm apart, to ensure the boards don't bow
- Stack units with banding and bottom supports aligned
- Pallets of cladding boards should not be stacked more than 4 pallets or 3m in height



## HANDLING

- Hyperion Cladding materials should be placed and not dumped when unloading
- When removing boards from a unit, lift the boards and set them down, do not slide boards against each other when moving them
- Carry Hyperion Cladding boards on the edge for better support
- During construction, do not slide or drag any equipment across the boards
- The surface of the boards should be kept free of construction material and waste to prevent damage
- As our cladding is quite long we recommend that two people handle the boards during transportation



## RECOMMENDED TOOLS FOR INSTALLING HYPERION CLADDING

Standard woodworking tools can be used when working with Hyperion Cladding. If you are unsure on how to use any tool, please consult the tool's manufacturer's user manual

- Circular Saw - we recommend a thin kerf 40-tooth alternate top bevel finish blade to achieve the cleanest cuts. If cutting Manticore plastic battens use a tungsten carbide blade
- Power Mitre Saw can also be useful for efficiency and bevelled edges
- Jig Saw
- Hand Drill - 3mm and countersink drill bits (can use all-in-one smart bit)
- Impact Driver (Use T15 secure drill bit supplied in all Hyperion hidden fastening packs, use low torque setting)
- Tape Measure
- Carpentry Square
- Spirit Level
- Safety Glasses and relevant Personal Protection Equipment (PPE)
- Pioneer Cladding Fasteners

# CALCULATING MATERIALS

To determine how much Hyperion Cladding material you will require, you can either use detailed plans or follow the method below. Alternatively, feel free to call one of our technical experts for assistance with planning your project by calling 0208 088 4888

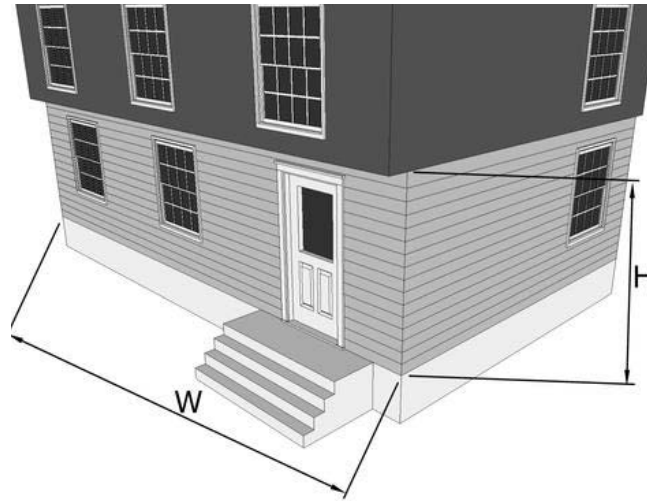

- 1 Start by measuring your proposed cladding area(s) height and width (as above)
- 2 Plan which direction to install your cladding: horizontally or vertically

The following example will use a cladding area of 11 m wide x 6m high:

- 3 If the boards are installed horizontally, divide the wall height by the visible width of the board (120 mm)

Height = 6m, then  $6\text{m} / 0.12\text{m} = 50$  boards high

- 4 Now multiply the width of the wall by the number of boards high (given above), and divide this number by the longest length of cladding board:

Width = 11 m, then  $(11\text{m} \times 50\text{ boards}) / 3.6\text{m lengths} = 153$  of the 3.6 m boards

- Always round UP the number of boards required
- If the wall width is less than our 3.6 m board and you want no butt joints across the wall, simply order the calculated number of boards high
- For multiple Cladding areas, follow the steps for each above and sum the quantities together

If you have multiple Cladding areas, follow the steps for each above and sum the quantities together.

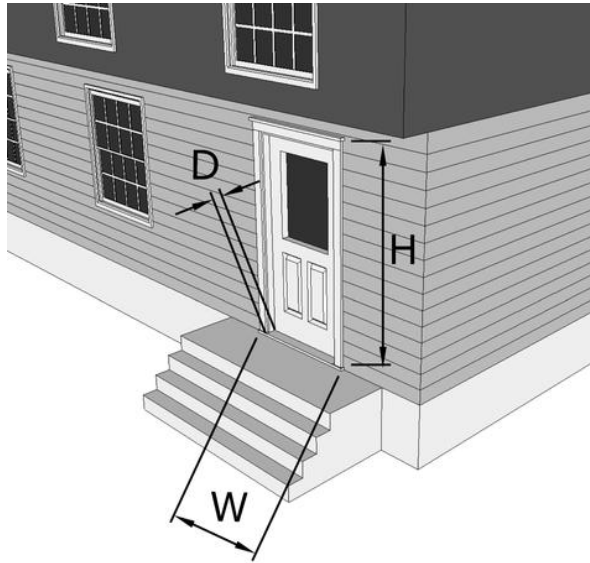

- 5** Now it is time to remove any openings from the cladding board total. If the boards are installed horizontally, divide the opening height by the width of the board (120mm)

**Door Height = 2m, then  $2\text{m} / 0.12\text{m} = 10$  boards high**

- 6** Now multiply the width of the opening by the number of boards high (given above), and divide this number by the longest length of cladding board:

**Door Width = 0.80m, then  $(0.80\text{m} \times 10 \text{ boards}) / 3.6\text{m lengths} = 2.22$  of the 3.6m boards**

- 7** Remove this amount from cladding board total (always rounding DOWN):

**Total amount of boards required =  $153 - 2 = 151$  of the 3.6m boards**

- 8** It is recommended that you add approx. 5% extra material to the total for a scrap factor

You may also require substructure, finishing materials and fixing screws. Below are our quantity recommendations:

- Battens / Joists – Require 9 linear meters per 5m<sup>2</sup> of Cladding
- Fascia Boards and Corner Nosing Trim or Edge board– 2 lengths per 5m<sup>2</sup> of Cladding
- Fixing screws – Require 7 per cladding board (600mm batten centres)

These are best estimates only, for more complex designs and features a drawing to scale may help you determine how many more cladding boards and accessories will be required.

# INSTALLATION - SPACING

Ensure the correct sized pilot holes are pre-drilled before screwing into all composite products to avoid splitting. Pre-drilled holes in cladding boards need to be at least 2mm wider than the screw thread used to allow space for thermal expansion of the boards

## SPACING AND EXPANSION GAPS

Due to natural expansion and contraction of material with changes in temperature, please ensure the following gapping requirements for all Hyperion Cladding products:

- Butt joints need to be min. 7mm for 3.6m length boards. When boards are trimmed down, the expansion gap should be min. 0.2% of the length of the board
- Plastic lumber batten butt joints should be gapped min. 20mm end to end
- A min. 20mm gap is required when abutting walls or other fixed objects
- A min. 20mm gap is required between the lowest board edge and the ground surface
- To allow air ventilation and drainage of rainwater, a cavity of no less than 38mm must be in place

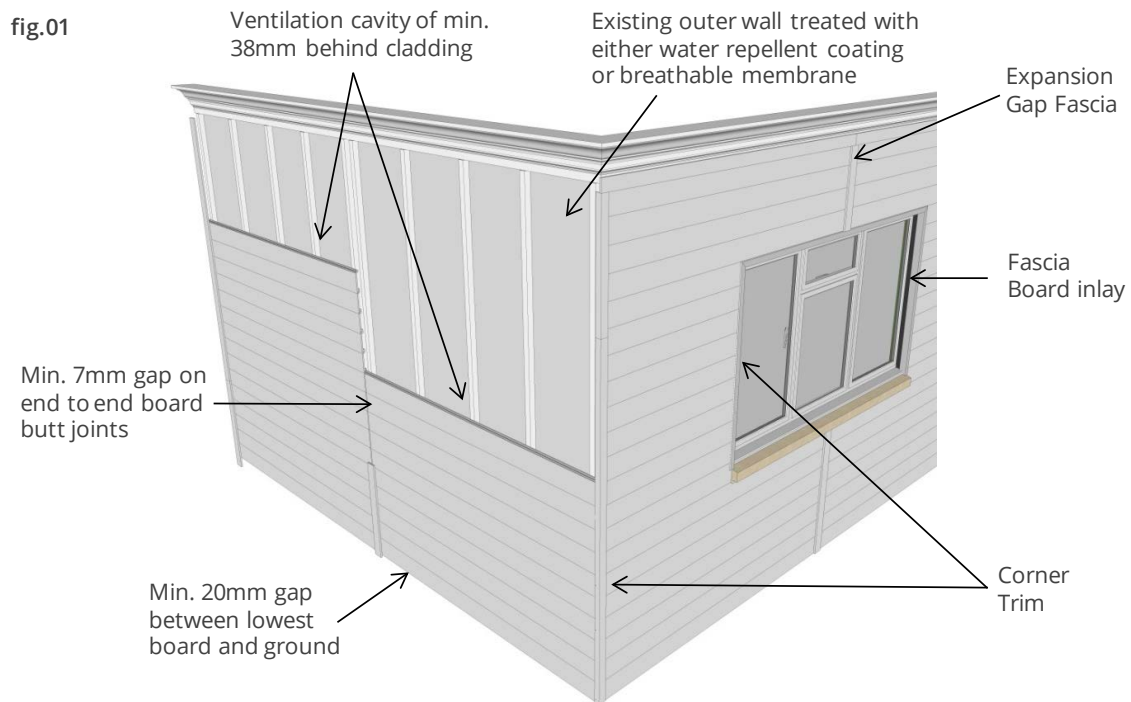

# INSTALLATION - SUPPORT STRUCTURE

## PLANNING CLADDING SUPPORT STRUCTURE

Hyperion Cladding may be fixed to a property using the following methods:

- 1 Preferably screwed to battens attached to sub-frame battening that is fixed separately to the wall
- 2 Screwed to battens fixed directly to the outer wall once a waterproof membrane/vapour barrier and non-compressible insulation is in place
- 3 For uneven or non-load bearing walls, the cladding may be fixed to battens on a self-supporting frame

### WATERPROOF MEMBRANE

- A water repellent coating or breathable membrane must be installed before battens are fixed, to protect walls from water penetration (**fig.02-03**)
- However if water repellent insulation is used, it is not essential to use a breather membrane between battens fixed to a cavity wall

### Hyperion Cladding can be fixed on recycled PLASTIC BATTENS OR TREATED TIMBER BATTENS

- Each batten must be fixed in a minimum of 3 places
- Never use plastic battens for general construction
- A ventilation cavity of min. 38mm must be in place behind the cladding boards (use battens min. 38mm thick) to allow air ventilation and unrestricted drainage of rainwater that may penetrate cladding
- Any timber used must be pre-treated by an industrial process in accordance with BS8417 for a BSEN335:1. Use Class 3 application - Wood Protection Association Commodity Specification Code: C6 (NBS as Z12/120)
- Insect mesh should be used on cavity openings

fig.02



Water repellent coating or breather membrane

Ventilation cavity of min. 38mm behind cladding

fig.03





## INSTALLING CLADDING SUPPORT BATTENS

- 1** Fix either recycled plastic or treated timber battens at a maximum of 600mm intervals to the supporting wall or structure (**fig.04**)
  - Consult a building professional regarding vapour barriers and insulation for your project
  - Where a vapour barrier is to be used, it should be breathable and positioned behind the battens to allow the cladding a minimum 38mm airflow
- 2** The first batten should be installed min. 20mm from the ground (no starter tray required)
  - Using suitable A2/A4 stainless steel countersunk screws, fix the battens into position at max. 600mm centres
  - Ensure all battens are level to the wall surface, using packers where appropriate
  - A double batten structure should be installed for cladding board ends (butt joints)
- 3** Install additional wall battening around windows and doors (**fig.05**)
  - To use the Edge board, double battening is required around corners and openings. To see more about edge board installation see **p.13**
  - For vertical cladding, we recommend using counter battening to allow sufficient airflow. For more about vertical cladding please see **p.13**

fig.04

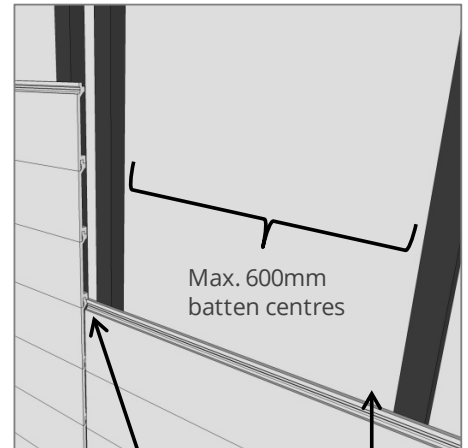

Double batten structure under cladding board joints

Ventilation cavity of min. 38mm behind cladding

fig.05



Additional battening around wall edges

## BEFORE YOU START

Hyperion Pioneer Cladding boards can be installed using screws alone (option 2), however for extra security you can also install the cladding using starter fasteners on the first board (option 1).

Please note Edge boards must be fitted before you install cladding, see **p.17** for more details.

### OPTION 1 Installing the First Board Using Starter Fasteners

**!** If you are not using Starter fasteners please move to Option 2

- 1** Mark level lines on the battens for the starter clips installation, we recommend the bottom of the starter clip is installed 30mm or above the ground surface to ensure the board will sit a min. 20mm above the ground (**fig.06-07**)
  - Ensure the starter clips are level
  - Install one start clip per batten
- 2** Once the starter clips have been installed slide the cladding board into the clips (**fig.08**)
- 3** Secure the top of the board:
  - Pre-drill the screw holes in the cladding board 2mm wider than the thread of the screws used (to allow for material expansion). These holes should line up with the supporting battens.
  - Fix to the batten using an A2/A4 Pan Head 8 gauge 38mm screw (max. 2mm head thickness) through the pre-drilled holes; be careful not to over tighten the screws (**fig.09**)
- 4** Once the first board is in place please **move on to step 1-3 on p.12**

fig.06

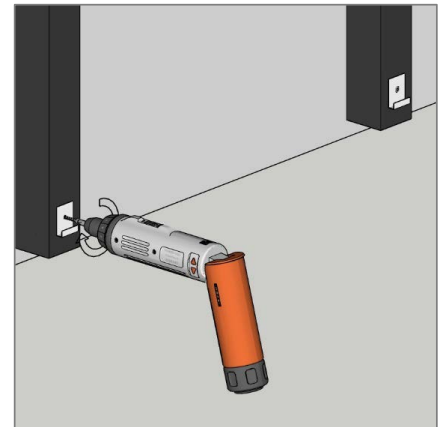

fig.07

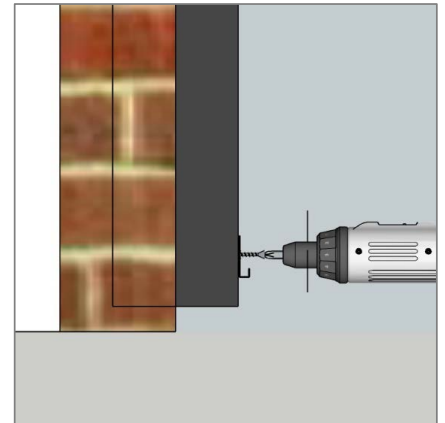
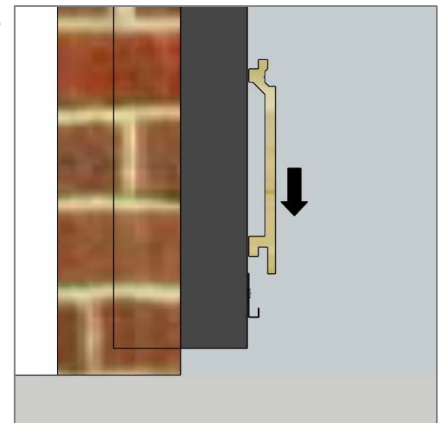
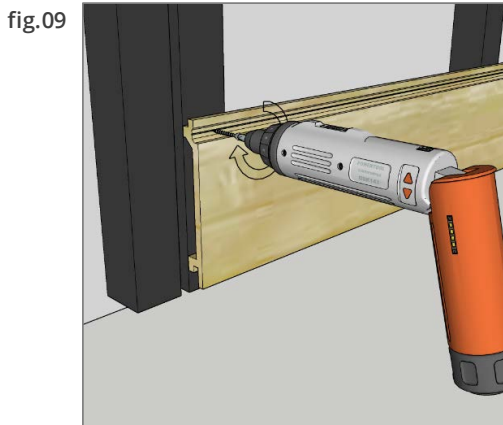

fig.08



## OPTION 2 Installing the First Cladding Board Without Clips

Pioneer composite cladding boards are rigid enough to be installed without the use of starter fasteners.



**1** Mark level lines on the battens for the first (lowest) board to be installed, ensuring the board will sit min. 20mm off the ground surface (**fig.10**)

**2** Pre-drill the screw holes in the cladding board 2mm wider than the thread of the screws used (to allow for material expansion). These holes should line up with the supporting battens

- Place the bottom cladding boards in position
- Fix to the batten using an A2/A4 Pan Head 8 gauge 38mm screw (max. 2mm head thickness) through the pre-drilled holes; be careful not to over tighten the screws (**fig.11**)

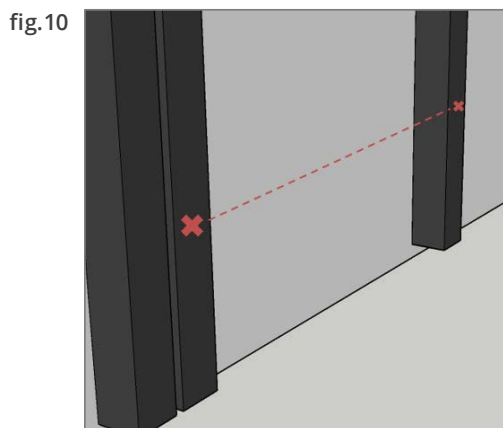

**3** Once the first board is in place please **move on to step 1-3 on p.12**

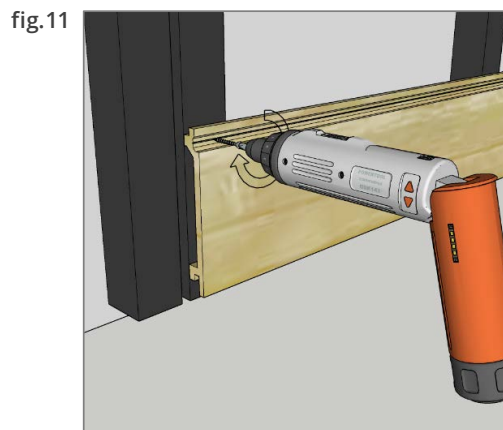

## INSTALLING THE REMAINING BOARDS

- 1 Once the first board is secured, line up the next board and slide into place.
  - Pre-drill the screw holes in the cladding board 2mm wider than the thread of the screws used (to allow for material expansion). These holes should line up with the supporting battens
  - Place the next cladding boards in position and gauge 38mm screw (max. 2mm head thickness) through the pre-drilled holes; be careful not to over tighten the screws (**fig.12**)
- 2 Repeat step 1, fixing all boards until the top (or side for vertical) edge of the wall.
  - Check the board is level before each board is fixed. Slight adjustments may be required (**fig.13**)
- 3 Around objects such as doors and windows you may be required to shape boards to fit (**fig.14**)
  - Edge boards must be fitted before you install cladding, see **p.17** for more detail
  - It is suggested to use fascia boarding anywhere where horizontal cladding meets a roofline, window ledge or is going to butt up against a horizontal edge/barrier. See **p.17** for more detail on installing edge board.

fig.12



fig.13



fig.14



## INSTALLING A RIPPED BOARD

This installation process is similar to that of a full cladding board. Slide the groove into the board below, pre-drilling and securing with a screw. Use a wooden packer and a long screw to secure the top of the board, ensuring that the screw is drilled through the ripped board, the packer, and the substructure behind. Use colour-matched screws to make them less noticeable.

## VERTICAL CLADDING SUPPORTS

For vertical cladding, we recommend using counter battening to allow sufficient drainage and airflow (**fig.15**).

- We recommend using battens with a 15° tilted top edge to shed water from the substructure and reduce water pooling

## VERTICAL CLADDING INSTALLATION STEPS

- 1 Always start your installation from the corner or edge of the design (**fig.15**)
- 2 Mark level lines on the battens for the first board to be installed, ensuring the board will sit min. 20mm off the ground surface
- 3 Once secure, place the next cladding board in place and repeat this process, (**fig.16**). Fix all boards until the end of the wall.

## FINISHING CORNERS AND WINDOWS

To finish off your vertical cladding around corners you will need to use Hyperion Corner Trim; the Edge Board is not a suitable solution for vertical cladding.

- Hyperion Corner Trim and Fascia Board can be used to finish corners, doors and window frames (**fig.17**)
- For more about finishing with Corner Trim and Fascia Board see **p.15-16**

fig.15

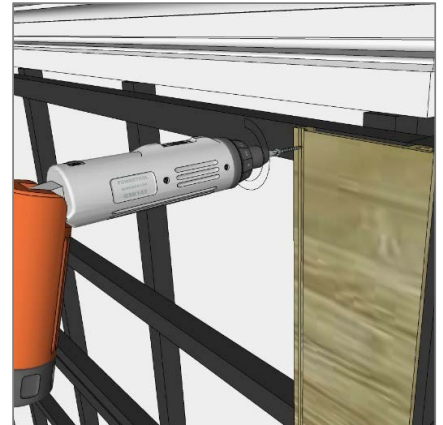
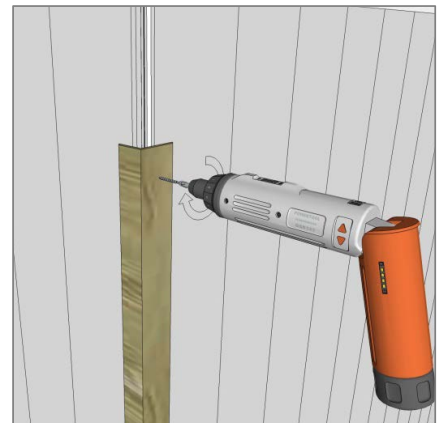

fig.16



fig.17



## COVER EXPANSION GAPS

- 1** Install a Hyperion Fascia Board to finish off and cover the top cladding board fixing groove (horizontally installed cladding only) **(fig.18)**
  - Cut down the Hyperion Fascia boards to size
  - Place over the groove of the top cladding board.
  - Pre-drill through the board and countersink
  - Screw into place with countersunk A2/A4 Stainless Steel screws
  
- 2** If required, you can use Hyperion Fascia Board to cover cladding board expansion gaps **(fig.19)**
  - Cut down the Hyperion Fascia boards to size
  - Place over the expansion gap to cover
  - Pre-drill through the board and countersink
  - Screw into place with countersunk A2/A4 Stainless Steel screws
  - For any openings to the ventilation cavity insect mesh should be installed
  
- 3** Install Hyperion Corner Nosing Trim to cover corners/edges **(fig.20)**
  - Cut down the Hyperion Fascia boards to size
  - Place over the corner to cover, pre-drill through the trim and countersink
  - Screw into place with countersunk A2/A4 Stainless Steel screws

fig.18

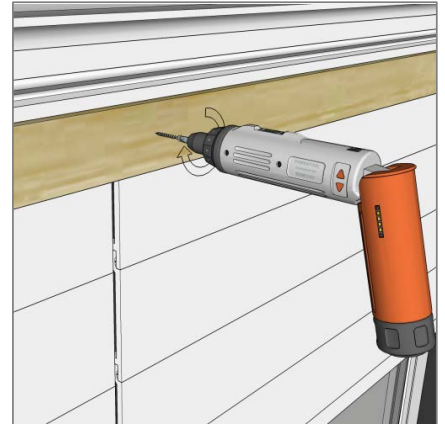

fig.19

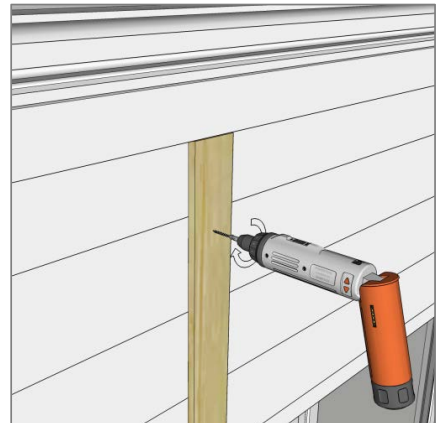
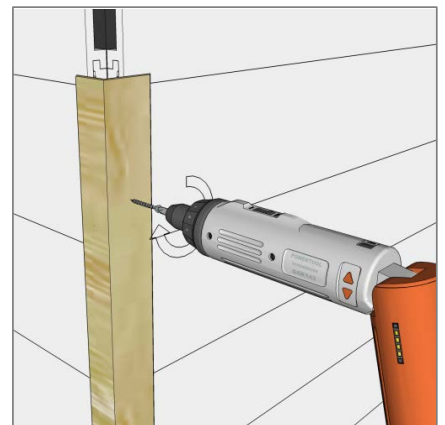

fig.20



## BEFORE YOU START

Additional battening is required around doors and windows, more battening may be required depending on your finishing option (**fig.21**).

It is suggested to use fascia boarding anywhere where horizontal cladding meets a roofline, window ledge or is going to butt up against a horizontal edge/barrier.

## OPTION 1 Hyperion Fascia Boarding

Hyperion Fascia Board can be used to cover the cladding board edges and around window frames. This option can also be paired with corner trim around window frames and doors

- 1 Measure the amount of fascia boarding required and cut down to size.
- 2 Place over the desired area. Make sure the edge of the fascia board sits flush with the cladded surface (**fig.22**)

Pre-drill and countersink the board

- 3
- 4 Screw into place with countersunk A2/A4 Stainless Steel screws

- 5 If desired the corner trim can then be placed over the fascia boards (**fig.23**)

fig.21

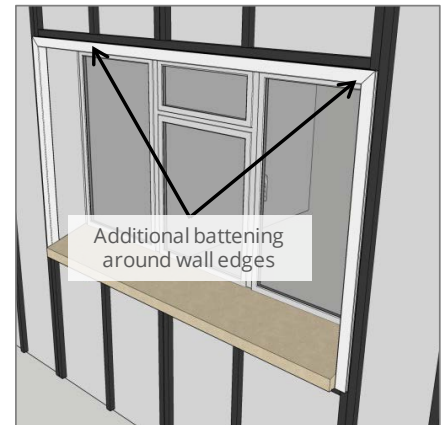

fig.22

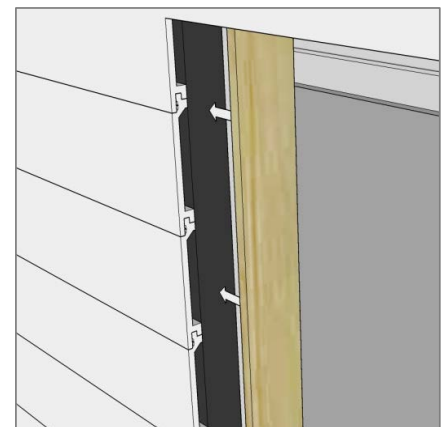
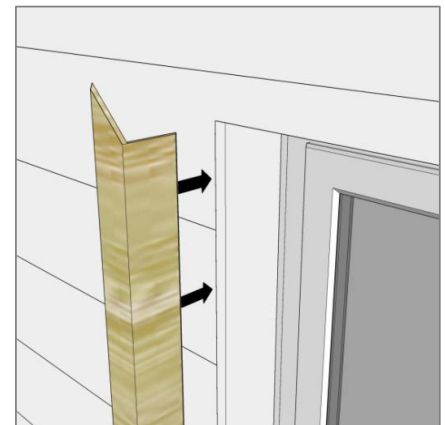

fig.23



## OPTION 2 Hyperion Corner Trim

Hyperion Corner Trim can be used on its own or with Hyperion Fascia Boards to cover cladding board edges and exposed substructure at corners, doors and window frames

- 1 Measure the required amount of Hyperion Corner Trim and cut down to size
- 2 Mitre down at 45 degrees, Corner Trim ends if being placed next to each other at wall edges (**fig.24**)
- 3 Place over the corner to cover, pre-drill and countersink through the trim (**fig.24**)
- 4 Screw into place with countersunk A2/A4 Stainless Steel screws (**fig.25**)
- 5 If you are concerned about visible screws, coloured screws and screwcaps are available from general builders merchants

Corner Trim can be combined with Fascia Boards to cover deeper window and door frames (**fig. 26**)

### SOFFIT INSTALLATION

Soffit installation will largely depend on the specific technicalities of your building. Make sure you have carefully measured the length and width of each board to the section you are going to install it. You must use a starter fastener to ensure secure installation (**p.10**). Follow the instructions on **p.12 or 13**, drilling the cladding boards to the soffit area as you install them, ensuring to pre-drill pilot holes and countersink. Border the area with fascia (**p.15**) or corner trim (**p.16**) to cover any corners that connect the soffit and external cladded wall.

fig.24

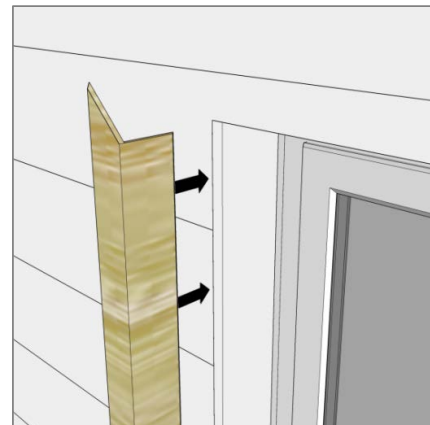

fig.25

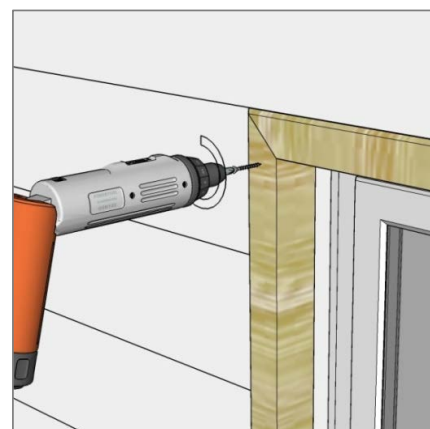
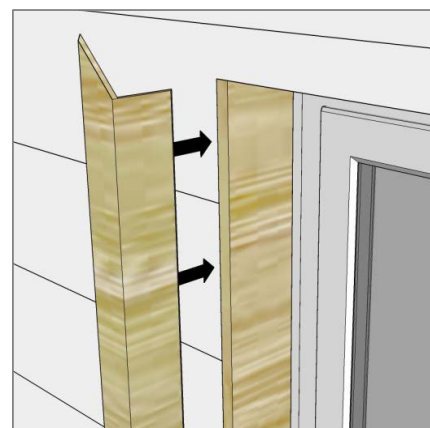

fig.26





## OPTION 3 Hyperion Edge Boards

Hyperion Edge Board can be used to create a flush finish for corners, doors and window frames. This option can use hidden fasteners for no visible surface screws

- 1 Edge Boards must be installed before cladding boards when used around corners, doors and windows
- 2 For this finish you must ensure that you double batten the area around the window frame or corners (**fig.27**)
  - Ensure the battening finishes 21mm away from the window edge to allow for the thickness of the Edge Board (21mm) (**fig.28**)
- 3 Cut the Edge Board to size for the corner. If placed in a window frame or door, mitre the end down to meet the end of a perpendicular board (**fig.28**)
- 4 If you do not want visible screws, you can use hidden starter fasteners to hold the board in place
  - Fix starter fasteners every 480mm along the batten of the corner or windowsill, so they can hold the inner edge of the Edge Board (**fig.27**)
  - Push the Edge Board into the starter fasteners (**fig.28**)
- 5 If you are not using hidden fasteners, pre-drill and screw directly through the board front or inner groove max. every 400mm (**fig.29**)
- 6 Fix the outer Edge Board by drilling at an angle through the nose of the board at a 45° angle into the substructure. (**fig.30**). We recommend securing the board every 400mm along the length of the joist
  - Ensure to pre-drill a hole before screwing
- 7 Repeat until the window frame is covered
- 8 Install the cladding boards to create a flush finish (**fig.31**)
  - You may be required to adjust the screw position slightly to avoid the cladding board back

fig.27

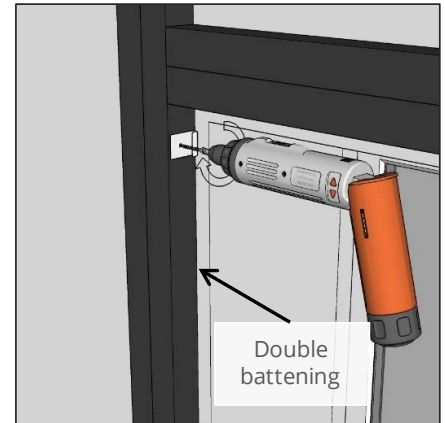

fig.28

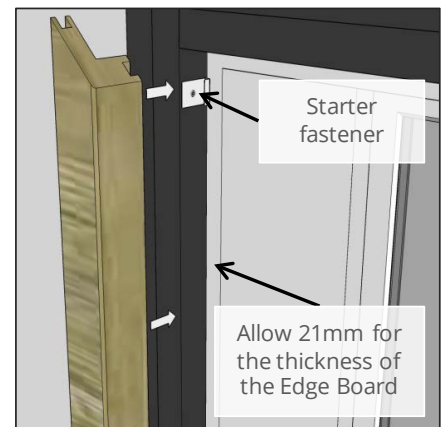
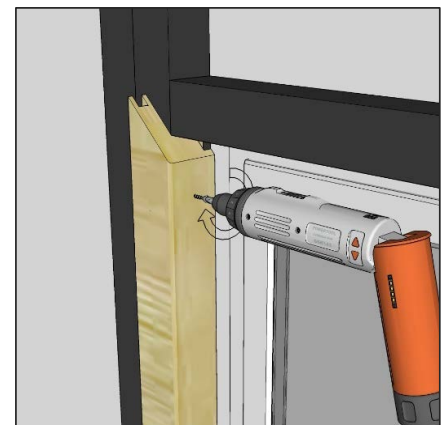

fig.29



## EDGE BOARDS FOR CORNERS

To cover a corner of wall with the Edge Board, that is to be cladded on both sides, you must add an additional batten on the corner (**fig.32 & 33**)

- The Edge Board must be installed before installing cladding boards
- Ensure you leave an expansion gap of 6mm when butt joining Edge Boards

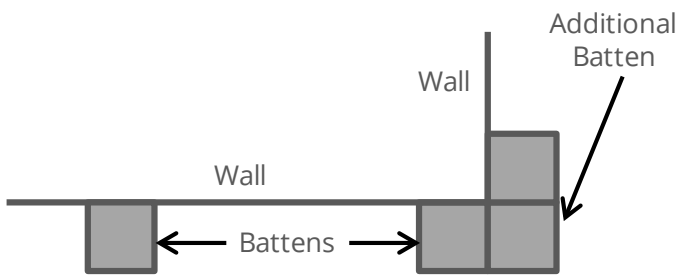

fig.33

## INTERNAL CORNERS

Internal corners do not need a corner trim or edge board. Place one board in the internal corner with the grooved end facing the wall and drill it down. Place the second corner board next to it as shown (**fig. 34-35**), drilling it into the batten behind. Remember to leave an expansion gap between the cladding boards (**p.7**).

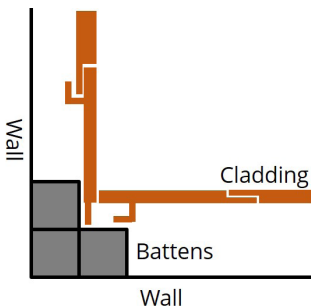

fig.34 vertical cladding

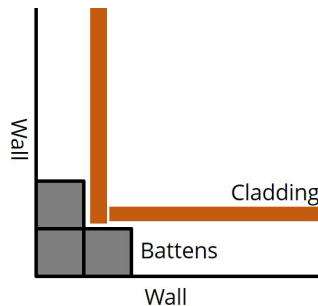

fig.35 horizontal cladding

fig.30

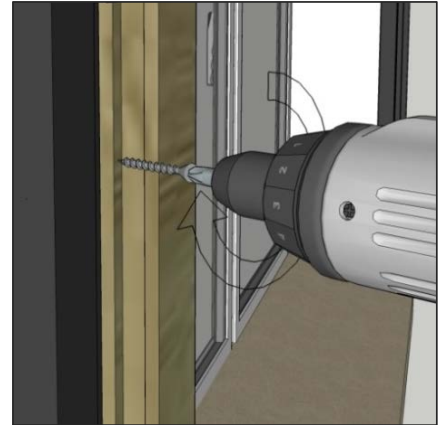

fig.31

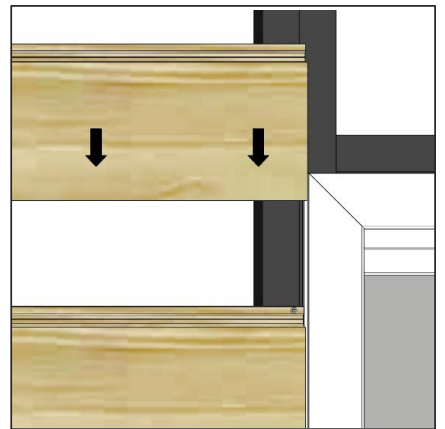
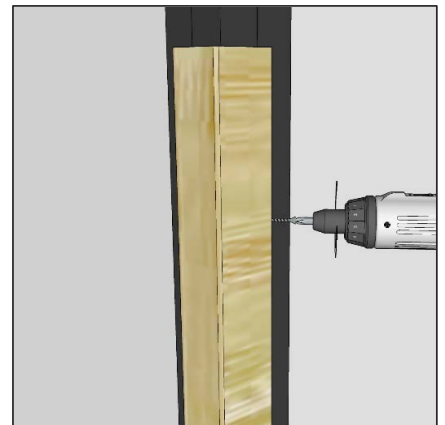

fig.32



**Q. Where can I use Hyperion Cladding?**

A. The versatile Hyperion product range can be used in a variety of locations, both residential and commercial. However as this is an external building covering, you must ensure you consult with your local building control to determine fire classification project requirements. Hyperion Cladding is classified D-s1, d0 Reaction to Fire (EN13501-1).

**Q. What colours do your products come in?**

A. Hyperion Cladding comes in a variety of colours. We have the natural browns: Oak and Walnut, then the modern greys: Granite, and Stone.

**Q. Will the colour fade over time?**

A. Hyperion Pioneer products will naturally lighten over the first 8-10 weeks and then will stabilize after this period.

**Q. How do your products react when exposed to water?**

A. Hyperion products are designed to take on very little water (c.1%). The products have a much lower absorption rate than timber which heavily reduces the likelihood of wet rot over a longer period of time.

**Q. Does the cladding require painting/treating?**

A. Hyperion products are already coloured so do not require painting at all. Also, due to the plastic content within Hyperion products there is no need for any further treatment. This also makes it easy to clean

**Q. Do you have recommended installers I can use?**

A. EnviroBuild has an extensive network of recommended installers who we trust to bring your plans to reality. We have chosen these installers for their high quality of work and professionalism, but as with any third party, we recommend that you follow your own precautions before entering into a contract with them.

**Q. What size boards does Hyperion Cladding come in?**

A. Hyperion Cladding boards come in 3.6m length boards. Bespoke length boards can be ordered subject to minimum order quantity and extra lead times.

**Q. Does the cladding use a starter rack?**

A. Hyperion Cladding boards do not require a starter rack, clips or fasteners. However for extra security you can also install the cladding using starter fasteners on the first board.

**Q. Anything else?**

A. For any other technical, installation or care questions, go to [www.envirobuild.com](http://www.envirobuild.com), call our technical team on **0208 088 4888**, or email us at [info@envirobuild.com](mailto:info@envirobuild.com)

**Q. Can I see Hyperion Cladding samples?**

A. Simply go to [www.envirobuild.com](http://www.envirobuild.com) to order your samples.



Hyperion products are low maintenance, however with a little cleaning you can help keep your outside space looking beautiful for longer. Please note that although Hyperion products are relatively colour stable, there may be some initial lightening as the product naturally weathers over the first 8-10 weeks.

With the proper safety precautions Hyperion products can be washed with either soapy water and a soft bristled brush or with a power washer (recommended max. 1500psi pressure). You should ensure to spray in the direction of the grain of the boards and use a fan tip nozzle (min. 6 inches from surface) along with the proper cleaning product.

### **Dirt & Grime**

Maintaining a clean, dry surface is the best method for combating dirt, grime and mildew build up, where a periodic cleaning is all that maybe required. Even though Hyperion products are formulated to inhibit mildew growth and staining, mildew stains can occur where moisture and dirt or pollen is present.

### **Spot Stains**

Many stains can be cleaned with soap or household de-greasing agent and warm water. Scrub and soak the affected area as soon as the stain occurs to ensure best results, then rinse off with warm water. For more stubborn stains we recommend using a composite specific cleaner for more effective stain removal. Only with very set stains, you may want to use coarse sandpaper (60-80 grit) and sand lightly (Pioneer range products only), always in the direction of the grain of the product.

Cleaned or sanded areas may lighten, which can require 8-10 weeks exposure to the sun to match the remaining product, depending on location and specific application. Due to the wood content, composite products, like any wood-based product, may experience a naturally occurring process called Extractive Bleeding (known as tea staining). This process can cause a temporary discoloration that will fade with time.

### **Scrapes & Scratches**

Surface scratches and abrasions will fade after weathering. However, scrape and scratch marks can be eliminated by using a wire brush or coarse 60-80 grit sandpaper (Pioneer range products only). Simply brush/ sand in the direction of the grain on the product until the mark has gone. The treated area will weather back in approximately 8-10 weeks.

### **Painting & Staining**

EnviroBuild does not guarantee or recommend anything applied to Hyperion products, however it is still possible for Hyperion products to be painted or stained. Wait until the product has completed its weathering process and ensure you have a clean and dry surface prior to applying any paint or stain. Always apply products in accordance with the manufacturer's application instructions.



ENVIRO  
BUILD

# **HYPERION**<sup>®</sup>

C L A D D I N G

ENVIROBUILD.COM



+44 (0) 208 088 4886