



ENVIRO
BUILD

HYPERION[®]

F E N C I N G

INSTALLATION &
MAINTENANCE GUIDE

CONTENTS

PRIOR TO INSTALLATION

Storage & Handling	3
Recommended Tools	4
Calculating Materials	5
Accessory Recommendations	6

INSTALLATION

SUB-FRAME INSTALLATION

Foundations for Fence posts - All ground types	7
Foundations for Short Height Fencing	8
Additional Options: Fence Post Spike	9

FENCING INSTALLATION

Fence Panels	11
On a Gradient	12
At an Angle	12
Onto Existing Posts	13

UPKEEP & FAQs

Maintenance & Care	14
FAQs	15



STORAGE & HANDLING

While composites are highly durable, to ensure their lasting beauty, please follow these important guidelines when storing, moving and working with Hyperion Fencing products



STORAGE

- Materials should always be covered until it is ready to be installed to maintain a clean surface. If stored outside use a non-translucent material
- All products should be stored flat and level, supported above the ground at 500mm intervals
- Battens used to separate and support stored material should be spaced no more than 500mm apart, to ensure the boards don't bow
- Stack units with banding and bottom supports aligned
- Pallets of fencing slats should not be stacked more than 4 pallets (3m) in height



HANDLING

- Hyperion Fencing materials should be handled with care when unloading
- When removing slats from a unit, lift the slats and set them down. Do not slide slats against each other when moving them
- Carry Hyperion Fencing slats on the edges for better support
- During construction, do not slide or drag any equipment across the slats
- The surface of the slats should be kept free of construction material and waste to prevent damage
- Each 1.8m fencing slat can weigh on average 4.5kg, so please ensure they are handled safely. We recommend that two people handle the boards during transportation

RECOMMENDED TOOLS



RECOMMENDED TOOLS FOR INSTALLING HYPERION FENCING

Standard woodworking tools can be used when working with Hyperion Fencing.
If you are unsure on how to use any tools, please consult the tool's manufacturer's user manual.

- Safety Glasses and relevant Personal Protection Equipment (PPE)
- Circular Saw - we recommend a thin kerf 40-tooth alternate top bevel finish blade to achieve the cleanest cuts
- Power Mitre Saw for efficiency and bevelled edges
- Impact Driver
- Tape Measure
- Adjustable Spanner
- Spirit Level
- Chalk Line
- Hand Power Drill
- 10mm masonry drill bit (for 80mm coach bolts)
- Sledge hammer and driving block if using fence post spikes

CALCULATING MATERIALS

To determine how much Hyperion Fencing material will be required, you can either use detailed plans or follow the method below. Alternatively, feel free to use our online calculator or speak to one of our technical experts on 0208 088 4888 for an accurate quote.

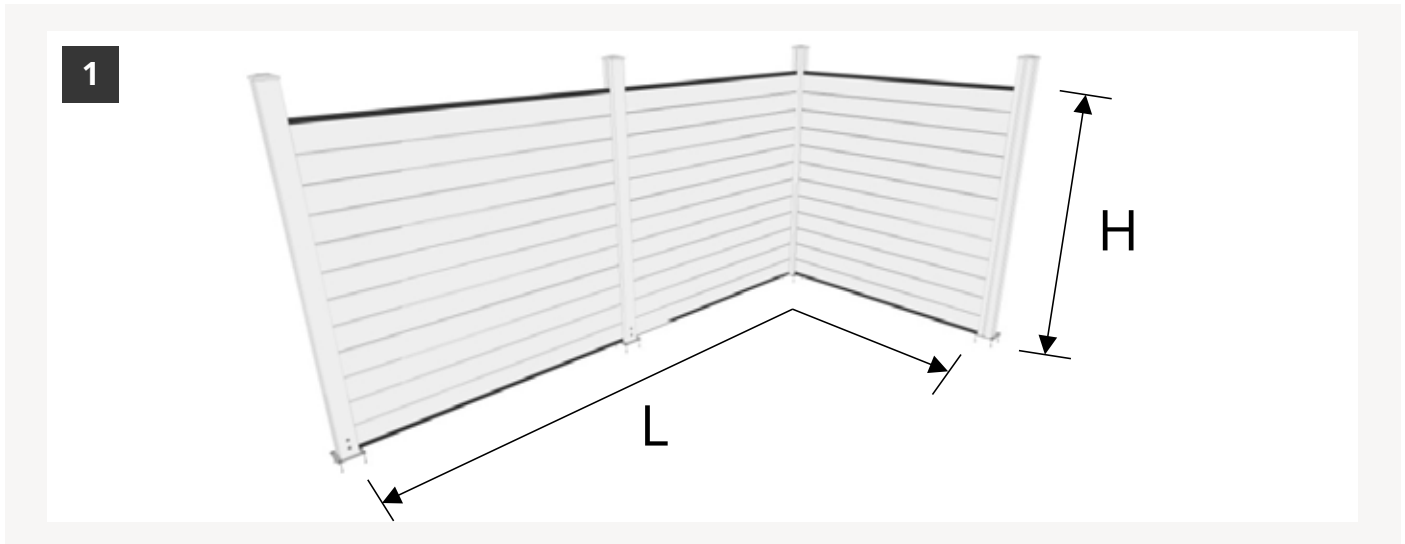

- 1 Start off by measuring the length and height of your proposed fencing area(s)
- 2 Once you have your fence length, divide this by the length of a full fence panel and post (we recommend using a height of 1.8m)

The following example will use a fencing area of 1.8m long x 1.8m high:

Length = 18m, then $18\text{m} / 1.8\text{m} = 10$ fence panel sections

- 3 Simply order this amount of complete fence panels on our website and all the required material will be delivered to site.

FENCES WITH A HEIGHT BELOW 1.8M

If you require a fence height less than 1.8m or have existing fence posts, then you need to divide the required fence height by the height of a fence slat (0.162m) and multiply this by the amount of complete fence sections (1.8m wide) you require.

The following example will use a Fencing area of 19m wide x 0.80m high:
Height = 0.80m, then $0.80\text{m} / 0.162\text{m} = 5$ fence panel boards per section
10 fence panel sections x 5 fence boards per section = 50 fence panel boards

ACCESSORY RECOMMENDATIONS

You may require additional composite fence posts, caps, stands, spikes and slat panel caps. Below are our quantity recommendations for Hyperion products:

ITEM	PRODUCT	PROFILE (MM)	SIZE OPTIONS	COLOUR OPTIONS	QUANTITY
	Fence post	100x100	2,400mm lengths	Granite, Oak, Stone, Walnut	1 per full fence panel plus 1 to finish the fence
	Fence post cap	120x120	One size	Granite, Oak, Stone, Walnut	One per post
	Post support	100x100	700mm height	Black	One per post if fence is <1m tall
	Fence panel cap	62x30	1,770mm lengths	Granite, Oak, Stone, Walnut	Two per fence installation
	Post inserts		2,400mm lengths	Granite, Oak, Stone, Walnut	Two per post
	Clips	n/a	One size	Black	Four per fence installation
-	Fencing Post Ground Anchor	42.4 x 1600	One Size	Steel	One per post if installing onto concrete

Please note: These are best estimates only, for more complex designs and features, a drawing to scale may help you determine how much material will be required.



CALCULATION RECOMMENDATIONS

- A drawing to scale may help you determine how much more material will be required
- Always round up the number of materials required
- For multiple fencing areas, follow the steps for each above and sum the quantities together
- If your design is sloped, it is recommended that you add at least 5% to the total fence slats required for wastage
- The type of foundation underneath the proposed fencing area will determine the post substructure needed to support the fence (**see p.8-10**)

SUB-FRAME INSTALLATION OVERVIEW

BEFORE YOU START

The type of foundation underneath the proposed fencing area will determine the post substructure needed to support the fence:

- For solid foundations such as concrete or masonry work it is recommended to use the Hyperion fencing post ground anchor. To see more about Hyperion fence post ground anchor installation see p.8
- If the fence is under 1m high, it can be installed using fencing post stands. To see more about this installation see p.9
- Fence post spikes can also be planted in soft foundations to support Hyperion fencing. To see more about post spike installation see p. 10



SPACING THE FENCE SLATS & POSTS

Due to natural expansion and contraction of material with changes in temperature, please ensure the following gapping requirements for all Hyperion Fencing products:

- An expansion gap of 4mm should be left between the fence slat and post.
- When measuring between post supports you need to allow for the panel cap with 4mm expansion spacing (1774) plus the 100mm post – 1874mm spacing in total

OPTION 1: HYPERION GROUND ANCHOR POLE FOR FENCES UP TO 2M

Hyperion Fencing posts have a round opening so fencing can be installed on a round metal pole of <44mm diameter. All fence slats are made to a standard 6ft, so when measuring between post supports you need to

- 1** Mark out the run of the post support centres using the fence section dimensions. Please note that the posts should always be on your side of the property boundary
- 2** Dig a hole with a size based on the ground conditions (fig. 3):
 - For the size of the hole, we recommend a hole that is 30 x 30cm wide and 60cm deep.
 - If you find solid objects while digging, such as rocks, use a prying bar to level them out
 - If you come across any tree roots, use a small narrow saw to cut them out
 - Tamp down the base of the hole until its solid
- 3** Once the hole is dug, place the round metal batton in the hole (fig. 4)
 - This should be at least 60cm below ground
 - A metal pole of <44mm diameter should be used
 - Using a spirit level, check the post supports are perfectly level and square to the run of the fencing
- 4** Secure the pole in the hole:
 - Double check that the pole is spaced correctly
 - Pour concrete into the hole to secure (fig. 5)
 - Wait for the concrete to set for at least 24 hours
- 5** Place the fence post onto the metal pole



OPTION 2: HYPERION POST STANDS FOR FENCES UP TO 1M

This option should only be used for fences with a max height of 1m. Hyperion Fencing post supports need to be fixed to solid foundations such as concrete or masonry work. All fence slats are made to a standard 6ft, so when measuring between post supports you need to allow for the panel cap with 4mm expansion spacing (1774) plus the 100mm post – 1874mm spacing in total

- 1** Mark out the run of the post support centres using the fence section dimensions. Please note that the posts should always be on your side of the property boundary
- 2** Place the metal post supports in position:
 - Using a spirit level, check the post supports are perfectly level and square to the run of the fencing
 - With the supports in position, use the 4 pilot holes in the post supports to mark the support fixing holes to be drilled
 - With a masonry drill bit, pre-drill the fixing holes to the correct depth (the diameter of the drill bit will depend on the type of rawl plugs you choose to use)
 - Firmly secure the post stand using the desired fixings, ensure there is no movement in the stand (fig.6)
- 3** Cut down the post to the desired height (fig.7):
 - Please note, the post should be no higher than 1m when using this installation method.
- 4** Place the fence post onto the fence post support (fig.8)

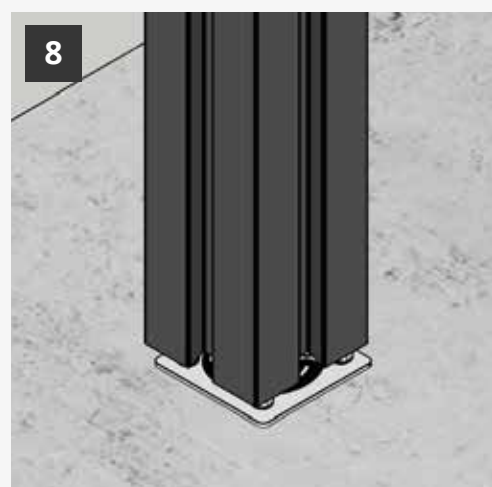
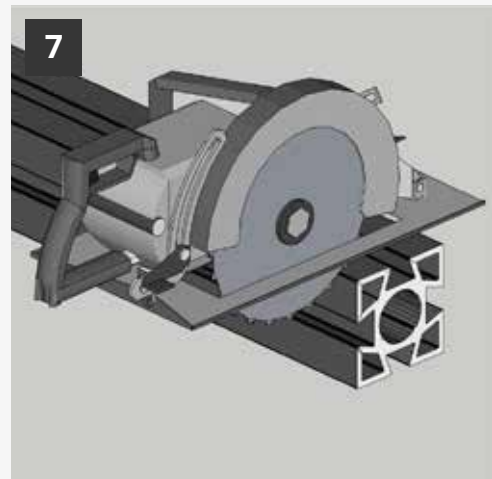
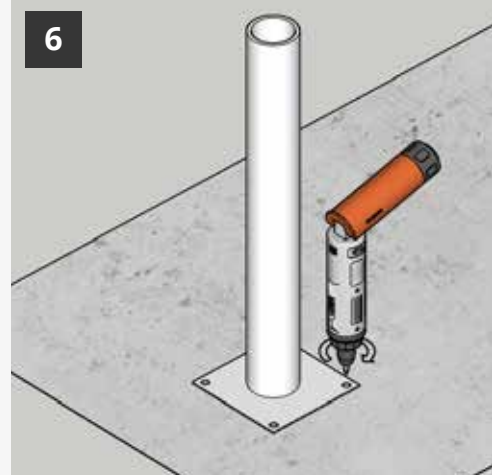

OPTION 3: FENCE POST SPIKES

For soft and non/concrete foundations you can plant the posts using fence post spikes. All fence slats are made to a standard 6ft, so when measuring between post supports you need to allow for the panel cap with 4mm expansion spacing (1774) plus the 100mm post – 1874mm spacing in total

- 1** Mark out the run of the post spike centres using the fence section dimensions above (1896mm). Please note that the posts should always be on your side of the property boundary
- 2** Measure the height of the fence post spike collar. Dig a small hole 1-2cm shallower than the height of the post spike collar, and wide enough around that you can tighten it once the post is in place (fig.9)
- 3** Place the fence spike into the hole. Place a driving block into the post spike and use a sledgehammer to drive the post spikes into the ground. Using a spirit level ensure all spikes are perfectly level and square to the run of the fencing (fig.9)
- 4** Cut down the post to the desired height (fig.4 - page 8):
 - Please note, the average post is 2.4m, but standard fence panels come to 1.8m
 - When installing on a flat surface, we recommend trimming the post down to 2m to achieve a flush look
- 5** Slide the fence posts into the post spikes. Tighten the fence post spikes until the posts are securely held and still square to the fence line (fig.10)
- 6** Fill in the remainder of the hole tightly packing the soil around the fence spike collar (fig.11)

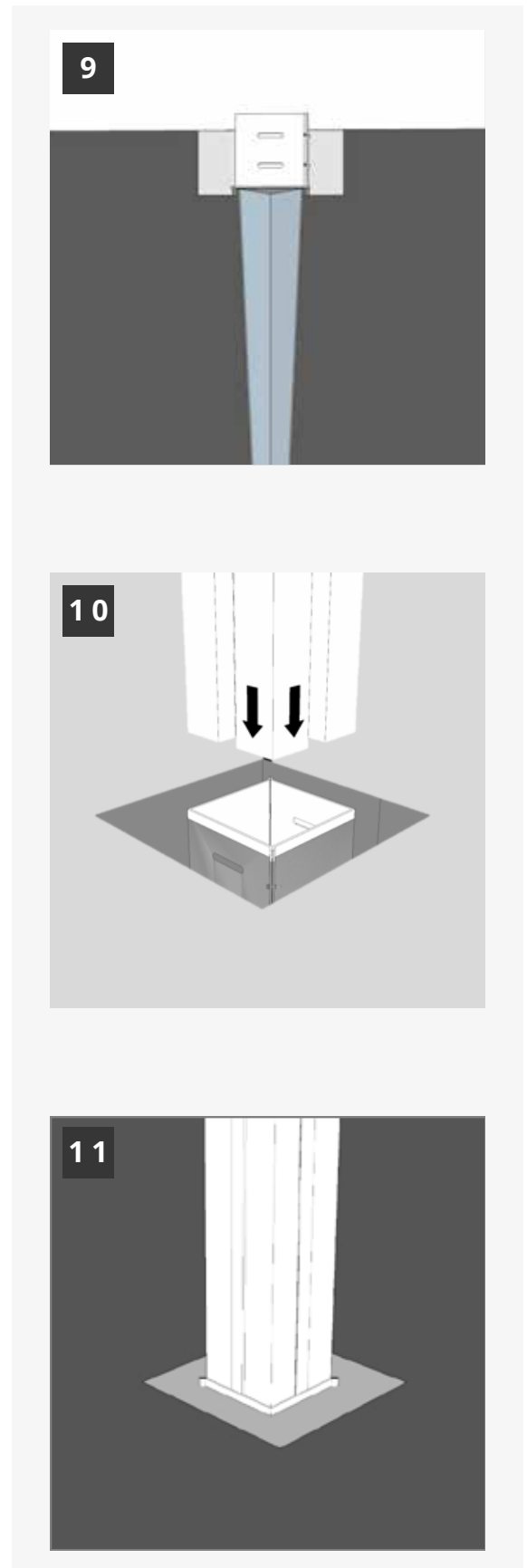

FENCING INSTALLATION: FENCE PANELS

With your subframe levelled and stable, you can now start installing your fence slats.

INSTALLING THE FENCE PANELS

- 1** Cut down the post to the desired height (fig.4 - page 8):
 - Please note, the average post is 2.4m, but standard fence panels come to 1.8m
 - When installing on a flat surface, we recommend trimming the post down to 2m to achieve a flush look
- 2** With the posts in place, prepare the panel cap:
 - Insert narrow part of panel cap clip into one side of the panel cap (fig. 12)
 - Insert another panel cap clip into the other side of the panel cap
- 3** Slide panel cap clips with the panel cap attached down the grooves in the opposing fence posts (fig.13)
- 4** With opposing fence posts and panel cap in place, you can now start to add the fence panels (fig.14)
 - Slide the initial fence panel down the post grooves into the panel cap
 - Once secure, slide the next panel down the post grooves onto the previous fence panel
- 5** Continue to slot in the remaining slats until the required fence height (fig.14)
 - 12 slats for a standard 1.8m (6ft) fence height

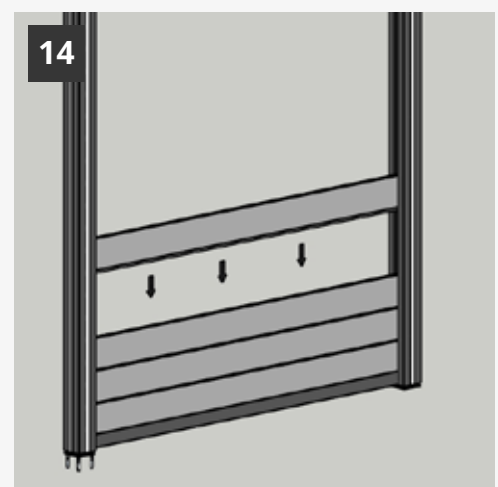
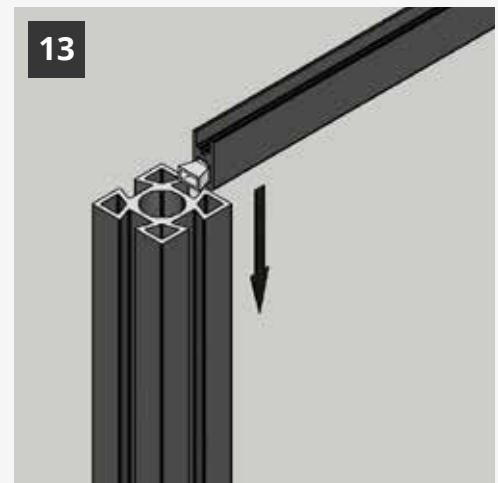
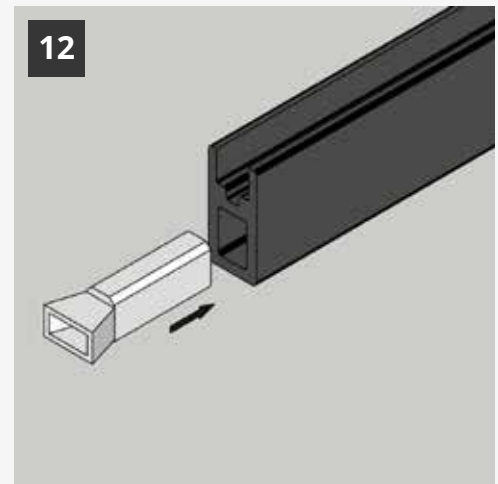

FENCING INSTALLATION: FENCE PANELS

- 5** With all the boards installed you can finish off the fence panel
- Add panel cap clips on both sides of the panel cap
 - Insert panel cap clips with panel cap down the grooves of the opposing posts
 - Ensure the panel cap is inserted with its groove down so it holds the final panel (fig.15)
 - Insert the fence post caps into the top of the fence posts (fig.16)
- 6** Repeat steps 1 - 4 until the entire fence is complete
- For a sleek finish, slide post inserts into any open grooves

INSTALLING HYPERION FENCING ON A GRADIENT

All fence slats and posts can be cut to size to help with slopes

- Either, the fence slat ends can be mitred to account for the angle of the slope, or
- The bottom fence panel slat(s) can be ripped to the angle of the slope (the bottom panel cap must be in place when installed)

INSTALLING HYPERION FENCING AT AN ANGLE

The panel clips we provide are made of plastic and can be trimmed to allow the fence panels to be at an angle other than 90 or 180 degrees (fig. 17):

- Insert narrow part of panel cap clip into one side of the panel cap
- Insert another panel cap clip into the other side of the panel cap

15

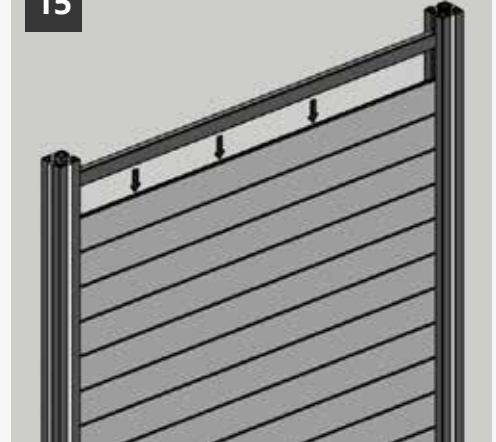

16

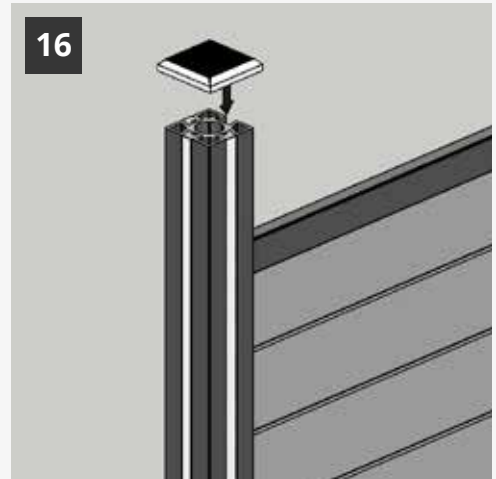

17

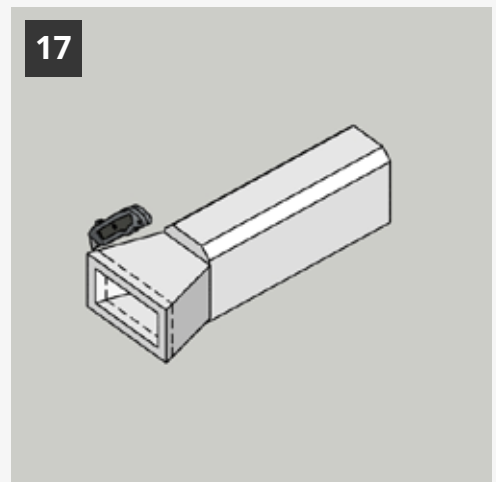

FENCING INSTALLATION: EXISTING POSTS

If your subframe is levelled and stable, you can start installing your fence slats.

INSTALLING ONTO EXISTING POSTS

- 1** As the fence slats are 1800mm in length, they will fit between existing standard concrete or wooden posts to replace worn out wooden fence panels:
 - Use aluminium post channels to secure the fence panels (fig.18)
 - Cut the aluminium post channels at the level of the final fence panel
- 2** Pre-drill 5 x 4mm holes along the centre edge of 2 aluminium post channels (per fence panel) (fig.18)
- 3** Screw the aluminium post channels to the inside edge of the existing posts (fig.18)
 - For concrete posts, pre-drill and insert rawl plugs to hold screws
- 4** Slide a panel cap down so it sits freely at the bottom
- 5** Slide down fence panels on top of the panel cap until the required height (fig.19)
- 6** Finish the panel by placing the panel cap on top of the final fencing slat (fig.20):
 - If you would like, you can attach the panel cap to the final fence slat by pre-drilling and inserting two screws in the panel cap





Hyperion products are low maintenance, however with a little cleaning you can help keep your outside space looking beautiful for longer. Please note that although Hyperion products are relatively colour stable, there may be some initial lightening of the Pioneer range products as the product naturally weathers over the first 8-10 weeks.

DIRT & GRIME

Maintaining a clean, dry surface is the best method for combating dirt, grime and mildew build up, where a periodic cleaning is all that may be required. Even though Hyperion products are formulated to inhibit mildew growth and staining, mildew stains can occur where moisture and dirt or pollen is present.

SCRAPES & SCRATCHES

Surface scratches and abrasions will fade after weathering. However, scrape and scratch marks can be eliminated by using a wire brush or coarse 60-80 grit sandpaper. Simply brush / sand in the direction of the grain on the product until the mark has gone. The treated area will weather back in approximately 8-10 weeks.

PAINTING & STAINING

EnviroBuild does not guarantee or recommend anything applied to Hyperion products, however it is still possible for Hyperion products to be painted or stained. Wait until the product has completed its weathering process and ensure you have a clean and dry surface prior to applying any paint or stain. Always apply products in accordance with the manufacturer's application instructions.

SPOT STAINS

Many stains can be cleaned with soap or household de-greasing agent and warm water. Scrub and soak the affected area as soon as the stain occurs to

ensure best results, then rinse off with warm water. For more stubborn stains we recommend using a composite specific cleaner for more effective stain removal. Only with very set stains, you may want to use coarse sandpaper (60-80 grit) and sand lightly, always in the direction of the grain of the product (be careful when sanding the wood grained fencing slats as this can remove the enhanced wood grain effect).

Cleaned or sanded areas may lighten, which can require 8-10 weeks exposure to the sun to match the remaining product, depending on location and specific application. Due to the wood content, composite products, like any wood-based product, may experience a naturally occurring process called Extractive Bleeding (known as tea staining). This process can cause a temporary discoloration that will fade with time.

CLEANING

With the proper safety precautions Hyperion products can be washed with either soapy water and a soft bristled brush or with a power washer (recommended max. 1500psi pressure). You should ensure to spray in the direction of the grain of the boards and use a fan tip nozzle (min. 6 inches from surface) along with the proper cleaning product.

Q. What colours do your products come in?

A. Hyperion Fencing comes in a variety of colours. We have the natural browns, Oak and Walnut, and the modern greys, Granite and Stone.

Q. Will the colour fade over time?

A. Hyperion products will naturally lighten over the first 8-12 weeks and will stabilize after this period.

Q. Does the Fencing require treating?

A. Hyperion products are already coloured so do not require painting at all. Also, due to the plastic content within Hyperion products there is no need for any further treatment. This also makes it easy to clean.

Q. How do your products react when exposed to water?

A. Hyperion products are designed to take on very little water (c.1%). Our ranges have a much lower absorption rate than timber which heavily reduces the likelihood of wet rot over a longer

period of time.

Q. Do you have recommended installers I can use?

A. EnviroBuild has an extensive network of recommended installers who we trust to bring your plans to reality. We have chosen these installers for their high quality of work and professionalism, but as with any third party, we recommend that you follow your own precautions before entering into a contract with them.

Q. Can I see Hyperion Fencing samples?

A. Simply go to www.envirobuild.com to order your free samples.

Q. Anything else?

A. For any other technical, installation or care questions, go to www.envirobuild.com, call our technical team on 0208 088 4888, or email us at info@envirobuild.com



